

ADJUSTABLE POST WRAP



TUSCAN
MANUFACTURING

INSTALLATION INSTRUCTIONS

Step 1 Safety Precautions

Review all local building codes.
Wear proper safety equipment.

Step 2 Prepare Mounting Surfaces

Make sure wood post is correctly installed.
Check post surface for obstructions (nails, screws, etc.) before covering post. (See Figure 1).
For min/max post wrap adjustment, see Technical Specifications.

Step 3 Cut Vinyl Post Wrap

Measure wood post to be wrapped and cut the Vinyl Post Wrap to the required finished length. (See Right) ASSEMBLED POST WRAPS ARE DESIGNED WITH A POSITIVE LOCKING FEATURE; ENSURE YOU ARE PREPARED FOR FINAL INSTALLATION PRIOR TO PROCEEDING.

Step 4 Install Vinyl Post Wrap

Start at one corner and insert male end into female end. (See Figure 2) Snap tight together until all four sections are installed. (See Figure 3)

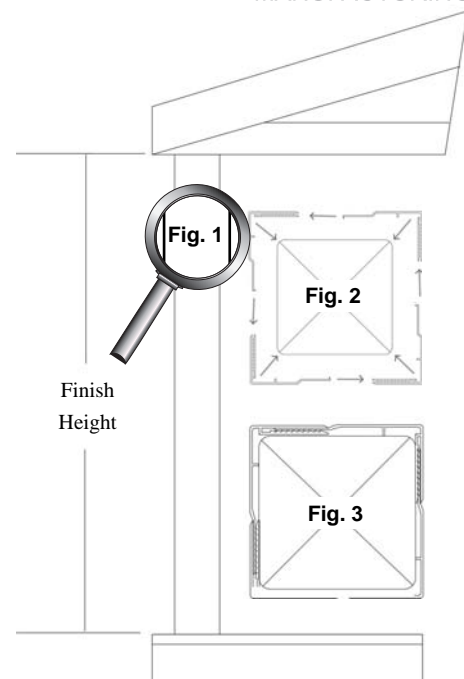

Technical Specifications

4" Post Wrap

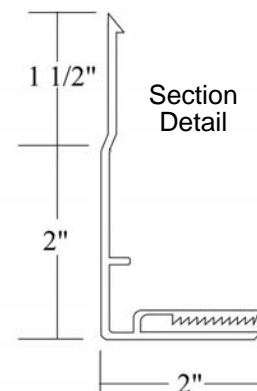
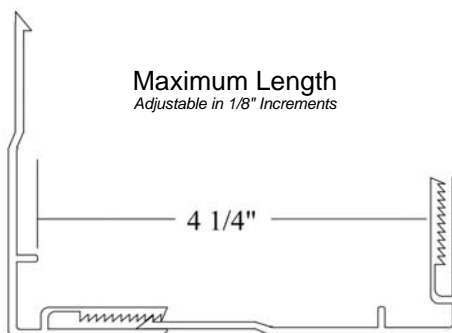
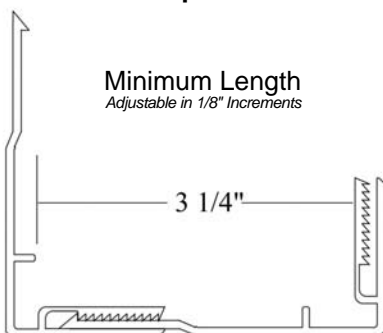

6" Post Wrap

